

ALFACIONADA

ALFA ROMEO OWNERS OF SOUTHERN CALIFORNIA

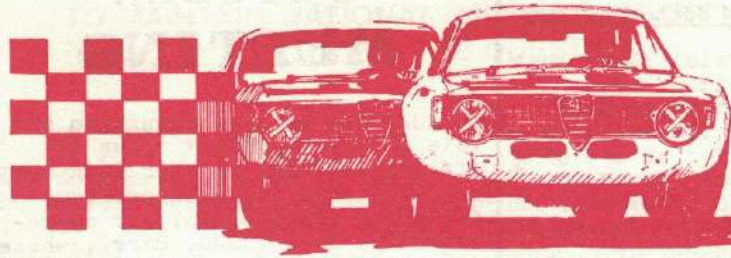

VOLUME 18 NO. 10 OCTOBER 1979 P.O. Box 261, Los Alamitos, Ca. 9072

the ROAR of the BEAR

by Rick "Bear" Clemente

In this edition of the "ROAR", I'll report on the National Board of Directors' Meeting, held in conjunction with Alfantasy '79 in San Diego this summer. The official minutes of that meeting are not out yet, so this report covers only the memorable highlights from a 10-hour meeting.

Our own AROSC Board of Directors has voted to present the general membership of our club with some options which I will cover in a separate article in this issue. (See Page 3).

The following is an outline and some explanations of actions taken (or not taken) by the AROC National Board of Directors this year:

1: Chapter Suspensions

This was some legal housekeeping, suspending several chapters until they properly incorporate, ect. No big deal.

2: Spouse Membership Officially Recognized

This clarified the bylaws and insurance questions. For each National member there is only one National vote; however, every member's spouse and family is a "member" for purposes of insurance. Local chapters may establish the voting-dues policy as they see fit. (Our policy is, and has been, that spouses have a local vote.

3: No "Local-Only" Memberships

Some chapters had two classes of membership. One local-National, and the other, a cheaper "local only" membership. This was in clear violation of the National bylaws and insurance policy. It does not affect us.

4: Competition Code

No action taken; referred to the Competition Committee.

Cont on Page 2

CALENDAR OF EVENTS

- Oct 21 AROSCD vs AROSC BEST DRIVE Challenge Malibu Grand Prix Anaheim. SPECTATORS WELCOME For info, call Sally French at (213) 372-3210
- 26 General Meeting, Alondra Park
VERY IMPORTANT MEETING!!!!
- 28 AROSC "Son of Hollywood Hills Mille Miglia" Rallye
- 30 Board Meeting, Cortes'
- Nov 2 ALFACIONADA Articles Due
- 10 AROSC Time Trial, RIR
- 23 Election Meeting and White Turkey Sale, Alondra Park
PLEASE NOTE DATE CHANGE
- Dec 8 AROSC Christmas Party

5: Evan Wilson, Editor of the "OWNER", Dismissed

This was a controversial issue that consumed much time. It is my own feeling that Evan got a raw deal, as most of the criticism surrounding the "OWNER" was for advertising rates (they don't begin to cover their own cost) and content. Neither of which fall within the responsibilities of the editor. Good luck finding as worthy a replacement. I'm sorry to see politics rule over good sense.

6: National Dues Increase

This is always a "hot" issue. The last dues increase on the National level was in 1972. At that time, the dues were increased by an amount greater than the needs anticipated for the following couple of years. The theory being that a surplus could be saved up and, as expenses increased, the surplus would cover a couple of years of deficit spending. This worked very well, and the surplus lasted until this year. The National Board voted this year to follow that same philosophy. The dues "split", i.e. that portion of total dues collected from members of local chapters, will be \$15.00 (up from \$7.50). The dues to "National only", i.e. members who don't belong to any local chapter (approximately one half of the National membership), will be \$25.00 (up from \$15.00).

Local chapters will still charge whatever each chapter decides they need to run their own organization.

7: "OWNER" Ad Rates

Ad rates will be raised so as to cost 110% of the production cost of their own space.

In summary I would like to point out that much of the business of running the National on a day-to-day basis is carried out by the Executive Committee and the Executive Secretary. The function of the National Board is really only to set the policy of the club.

OCTOBER MEETING

In addition to the discussion and vote on the important issue of affiliation, the October 26th meeting will have a slalom program, featuring Barry Klein, our representative to SCC SCC. Barry, whose column "Slaloms and Such" appears regularly in this newsletter, will be showing several movies on this fun sport. If slaloming sounds like something you might like to try, come on out!!!

THIS IS A VERY IMPORTANT MEETING- DO NOT MISS IT!!!

NOTICE:

DUES INVOICES ARE NOT INCLUDED IN THIS NEWSLETTER. DO NOT PAY DUES TO NATIONAL UNTIL AROSC RESOLVES THE AFFILIATION ISSUE.

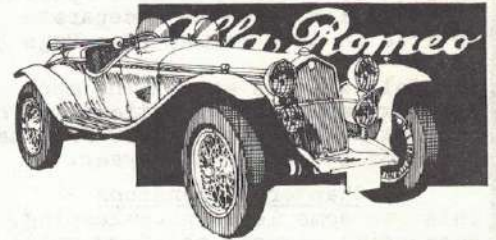

ATTENTION!

THE ANNUAL ELECTION MEETING AND WHITE TURKEY SALE HAS BEEN RE-SCHEDULED FOR NOVEMBER 23rd. SO MARK YOUR CALENDERS, AND PLAN TO ATTEND THIS VERY IMPORTANT MEETING.

TO MAINTAIN NATIONAL AFFILIATION, OR NOT- THAT IS THE QUESTION



by Rick "Bear" Clemente

In a move precipitated by the 100% increase in dues paid to the National, AROC, the AROSC Board voted at their October 2nd meeting to poll the General Membership of AROSC on the issue of chapter affiliation with the National organization.

Here are a few observations of my own, not meant to be pro or con, but only my thoughts and some background on the subject. There will be time set aside at the October meeting for a thorough discussion of the subject and a vote will be taken following the discussion period. The vote will be binding, and the majority of votes cast will be the deciding factor. So, if you feel strongly about this, DO NOT MISS THE OCTOBER MEETING (8:00 PM, October 26th, 1979, Alondra Park Clubhouse, 3850 Manhattan Beach Boulevard, Lawndale).

Here are my comments. The direct "visible" benefits to us of being affiliated with the National are: #1. The "OWNER", National newsletter. The quality of the paper is quite good for a 4,000 member club. The content is what the membership makes it. The editor is being replaced, and the National Board has created a committee to improve the "OWNER". #2. The National Convention. This is always a good event, though sometimes a long way to go.

The last visible benefits are: #1. The insurance supplied through National. #2. Across the country, the National provides technical assistance through the "Tech Hot Line" and a good technical library. This service is undoubtedly valuable to those living in the hinterlands, but with our own size and resources, not often of use to us here in Southern California.

The National pays a "rate per member" for the insurance. This same policy is probably available to AROSC at a slightly higher rate (because we have fewer members).

So what we get for \$15.00 per year from the National is the "OWNER" and the spiritual brotherhood of belonging to a National organization. I did not regard this as insignificant.

We will set aside as much time as necessary at the October meeting to fully air the views of our membership and vote on this issue.

If we stay in the National, the combined dues will go up to \$30.00 per year.

If we leave the National, we will be able to provide our own insurance, improve our newsletter, and maintain our other regular activities, and keep the dues at the current \$20.00 per year level.

If we leave the National and some of our members wish to retain their National membership as well as their membership in AROSC, the total cost to such an individual will be \$45.00 a year.

I remind you again that action will be taken, based on the results of the vote. BE THERE!!!



TECHNICAL TIPS

A \$4 Substitute For a \$50 ALFA Tool

by Karl Blasius

Amateur mechanics who (like me) wish to save a few bucks by changing the fuel injection pump belt on their Alfettas may have been encouraged to give it a try by Dave Vegher's description of the operation in the July Alfacionada. If, however, you pursued the matter beyond reading about it, you may have been shocked by the \$50+ price tag of the ALFA tool "Mr. Wrench" tells us to buy. (Maybe he did warn us, "Now comes the hard part. Buy from your ALFA dealer tool #A-30510..." Back to the point of this article.) That tool is a sturdy gear puller short enough to operate in the 3" of clearance between the front of the injection pump pulley and the back of the radiator. (That's the clearance in my '76 sedan, '78 and later sedans may have more space.)

I've found a substitute tool which should be satisfactory for the occasional mechanic and will only set you back about \$4 plus one half hour in your workshop. The tool is a steering wheel/gear puller marketed by J.C. Whitney for \$2.98 (p. 61 of the current catalog, stock #88-7029X). From the kit you'll use the 3 3/4" long puller main frame (Figure A) and the 1/2" diameter center screw (Figure B). Ignore the variety of 3 1/2" long screws which come with the kit, and buy two 3/8" bolts about 2 3/4" long. For each bolt also buy two heavy duty 1" diameter washers and a nut. These bolts go through holes in the injection pump pulley and the open ends of the gear puller main frame, one washer behind the pulley and one in front of the puller frame (Figure C).

A. GEAR PULLER MAIN FRAME

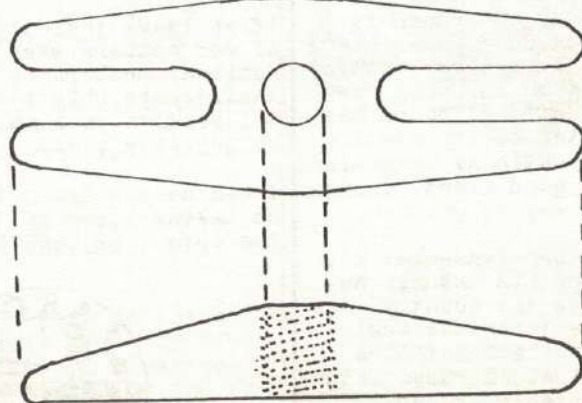

B. CENTER SCREW, BEFORE:

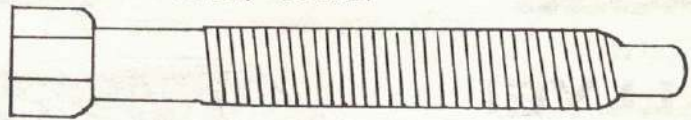

AFTER:

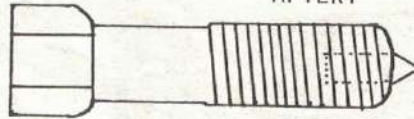

C. MODIFIED GEAR PULLER IN USE:

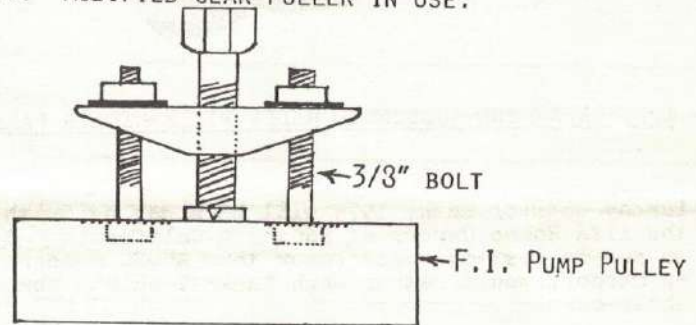

To fit into the limited clearance in front of the pulley, the center screw of the gear puller must be shortened from $4 \frac{3}{4}$ " to about $2 \frac{3}{4}$ ". This is accomplished by sawing off the end of the screw to shorten it about $2 \frac{1}{2}$ " and then adding a new centering guide about $\frac{1}{4}$ " long (Figure B). I drilled a hole in the end of the shortened bolt and inserted a piece of nail with a little silicone chalk to keep it in place.

To engage the gear puller you'll need to push one bolt with washer through the back of the pulley, rotate the pulley 180°, then push the other through. Put the nuts and washers on the ends of the bolts and slip them over the ends of the main frame. With the center screw against the pump shaft (Figure C) a slight turn will pop off the fuel injection pump pulley.

AROSC RALLYE!



THE SON OF THE HOLLYWOOD HILLS MILLE MIGLIA RALLYE

Sunday October 28th, 1979 will be a day of truth for the Alfa Romeo Owners of Southern California. A day to put to rest the ugly rumor that AROSC members no es macho...would rather wash their T-shirts than drive their cars.

It will be the day of "the rallye"...a two to three hour drive through the most famous hills this side of Rome...a day to test whether you deserve to own an Alfa Romeo. The rallye will combine Monte Carlo and Gimmick, and just maybe, a leg of TSD. All you need is a couple of pencils, something to write on, a good set of maps, a sense of humor, and.....guts.

You should come with a full tank of gas. That will get you through the day, home, and to work the next day, and probably then some unless you live in the most famous hills east of Hollywood.

ENTRY BY ADVANCE RESERVATION ONLY, and must be made no later than October 20th, 1979. Call John Ireland (213) 874-1445 evenings, or (213) 464-0101 and leave message. I will return all calls. The entry fee is \$5.00 per car. The fun you have will be priceless. Everything about this Rallye will be a surprise, so the only way to find out where it begins, or at what time of day to meet, is to call me.



ENTRY FORM FOR TIME TRIAL # 4

Print last name

Date Nov. 10, 1979

Schedule 7:00 - 7:15 All Novices in line for TECH INSPECTION
 7:30 - 8:15 All others in line for TECH INSPECTION***
 8:30 - 8:45 Drivers' Meeting - MANDATORY
 8:45 - 9:15 Track Orientation
 9:30 - 12:00 Practice
 12:00 - 1:00 Lunch
 1:00 - 4:45 Warm-up and TIMED RUNS(5 laps)
 5:00 Awards Presentation and CLEAN UP

Fee Single \$20.00 Mixed Couple \$35.00
 ***Entry Deadline Midnight Nov. 6 (received by AROSC)
 Late Entry Penalty Fee - \$5.00 per driver
 ***Late Tech Penalty: your fastest lap will be disqualified

Driver #1 Name _____
 Address _____
 Phone () _____

Driver #2 Name _____
 Address _____
 Phone () _____

Emergency In case of emergency, the Club should contact:
 Name _____
 Address _____
 Phone home() _____ work() _____

ALFA Year and Model _____ Disp. _____ cc.

Class Class _____ Class pts. _____
 I must file a new class sheets because I have made modifica-
 tions since completeing the last for. YES () NO ()

I understand that my entry fee is NOT REFUNDABLE and I will abide by the rules of the AROSC Competition Code.

Driver #1 _____ Driver #2 _____ Date _____

Please return this form with entry fee. Make checks payable to AROSC.
 Send to: Nancy Vegher
 2012 W. 234th St.
 Torrance, CA 90501

ALFA OF SANTA MONICA



exclusive Alfa Romeo Sales, Service and Parts
Catering to the Alfa Romeo Enthusiast



1115 WILSHIRE BOULEVARD

Sales Department open
Mon-Fri 8:00 am - 8:00pm
Sat 10:00am - 6:00pm

SANTA MONICA, CALIFORNIA
90403

Parts & Service open
Mon-Fri 8:00 am - 11:30am
12:30 pm - 5:30 pm

phone 393-0493
LA number 870-4771

VELOCE MOTORS WEST

Alfa Romeo Service



- * EXCELLENT MAINTENANCE SERVICE
- * SPECIALIZED STREET/FULL RACE PREPARATION
- * COMING SOON: ENGINE DYNO TUNING
- * CATERING TO TIME TRIAL ENTHUSIAST AND STREET RACER ALIKE
- * FRIENDLY AND PERSONALIZED SERVICE

home of
the
1977
AROC
National
CHAMPION

For an Alfa Romeo that runs as true as the legend
behind it, call DAVE VEGHER (213) 539-0700
MON.-FRI. 8:00 AM. - 6:00 PM.

VELOCE MOTORS WEST 1647 West Sepulveda
(UNIT #4) Torrance, California 90501

**VELOCE
MOTORS
WEST**

TIME TRIAL REPORT



by Dave Vegher

Our third Time Trial of the year was graciously sponsored by Alfa of Santa Monica. This dealership has filled the void in the West Los Angeles area created by the passing of Otto Zipper. Rolf Keilnecker is the owner of this thriving establishment, and I would personally like to thank him for his consistent support of AROSC as well as the Time Trial Program.

As we drove out to RIR early Saturday morning, intermittent raindrops pelted our van's windshield. This threat of rain obviously kept some of the not-so-stalwart competitors at home. However, over twenty-five enthusiasts showed up at 7:30 A.M. to challenge the curves of the Short Course.

Some new and some old faces appeared at the track that day. Bill Kohl, one of the founders of the Time Trial Program, took over two years to return to RIR with his sleek Class A 1969 Spyder. Verne Cochrane again appeared with his very fast Class D Turbo 1750 Spyder. Allan Gott, who never misses a chance to go fast, also showed up in his 200,000 mile young GTV.

New faces were many, as lots of novices have been trying their hand at high speed driving. Henry Manney, son of the famous writer, arrived in a new Alfetta GT with no safety equipment. Henry borrowed spare belts and shoulder harnesses from

other competitors and drove impressively. Nancy Mueller, another first-timer, was not so lucky. She totaled her 1978 2000 Spyder while negotiating the difficult corners of the famous esses. Her car flipped several times, but she and her passenger both walked away, shaken but unhurt. This speaks very highly for our stringent safety requirements, which have to be met by every car. I just can't see clubs who don't enforce these rules or don't require a roll bar in an open car.

In Class A Bill Kohl and John Samson shared a ride in Bill's car. Plagued with handling problems, Bill turned a respectable if not rewarding 1:47.43.

In Class B Tom Hines bolted some slicks on his 1600 GTA and flew to a Top Time of Day 1:43.65. The two TZs in Class B were nice to watch, but were disappointingly slow.

Tom Hines running again, on street tires this time, drove beautifully to a close win for Class C. Kent Jamison drove a fast, but sputtering 2000 Spyder to second place.

In Class D Verne Cochrane's Turbo just squeaked by Phyllis Gaylard's GTV.

Class E saw the upset of the year. Dan Bernstein, driving with a smoothness and confidence never seen before, outdrove a long-time nemesis Rich Washington. Dan's time was a four-second improvement over his last best time for this same track. Way to go, Dan.

In Class F Andy Steben flew to an easy win with a 1:58.90. And in Class G second-time novice Tom Lipkis, previously called "Spin Out", drove without incident to a win. Charlie Thieriot could do little to stop Tom, as his oil filter spun loose on the second of his timed laps.

Cont on Page 10

"Time Trial" Cont from Page 9

Well, that's about it for this month. Look for news about a big 2-day school and time trial at RIR or Willow Springs in February. There will probably be paid course workers

as well as a qualified instructor for every 2 or 3 students. Look for information on this event; it will be a blockbuster.

See you at the next Time Trial, on November 10, 1979.



AROSC TIME TRIAL #3
SPONSORED BY ALFA OF SANTA MONICA
RIVERSIDE SHORT COURSE
SEPTEMBER 29, 1979



(N) Novice

Class A	Bill Kohl	1750 Spider	1:47.43
	John Samson	1750 Spider	1:53.02
Class B	Tom Hines	1600 GTA	1:43.65 TTOD
	Dave Vegher	GTZ	1:50.29
	Rocky Chisholm	GTZ	1:51.35
Class C	Tom Hines	1600 GTA	1:50.31
	Kent Jamison (N)	2000 Spider	1:52.86
	Scott Gray	1600 GTA	1:55.21
Class D	Verne Cochrane	1750 Spider	1:57.34
	Phyllis Gaylard	2000 GTV	1:57.38
	Allan Gott	2000 GTV	2:00.17
Class E	Dan Bernstein	1750 Spider	1:57.17
	Rich Washington	2000 Spider	1:57.41
	Raul Perez	1750 GTV	2:09.74
Class F	Andy Steben	2000 GTV	1:58.90
	Henry Manney (N)	Alfetta GT	2:01.64
	Bill Biggs	1750 Spider	2:03.24
Class G	Tom Lipkis (N)	1600 GTV	2:03.00
	Charlie Thieriot	Alfetta Sedan	2:03.15

10% OFF TO AROSC MEMBERS

Alfas a Specialty!



ROTARY STOCKS A
LARGE SUPPLY OF ALFA
PARTS AT COMPETITIVE PRICES



ROTARY IMPORTS
Parts and Accessories for Foreign Cars
3570 E. Cerritos, Los Alamitos, California 90720
CALL FOR PRICES (213) 596-4434 (714) 826-4961



FOR SALE

1971 GTV Red/tan, 4 new CN-36-185/14s, 20,000 mi on 2 Liter eng, 45 DCOE Webers, 4 new Shelby Mini-Europe mags, AM/FM cass spoiler - A jewel of a car - \$4350 /OBO. Raul (213)670-1515 (x6133) days, (714)951-6874 eves

Four CN-36 Pirellis with 1/8" tread on them - good for slaloming & street - approx 10,000 Miles left on tread - \$50.00 the set Raul (213)670-1515 (x6133) days (714)951-6874 eves.

1967 Duetto, Konis, HD swaybars, adjustable upper arms, Ward springs, Wootten rollbar, oil cooler, new top, BWA, competition harness. Tatty cosmetics but lots of fun to drive. \$1000. Neil (213)595-1402.

(213) JOE CANNONE Prop.

ALFA ROMEO SERVICE

GITA Sports Car

18734 VENTURA BLVD. TARZANA CALIF
(Between Crebs and Yolanda streets)

ALFACIONADA

LBGP '80 TICKETS



AROSC has reserved a block of 300 seats in Grandstand 28 for the 1980 Long Beach Grand Prix. And for only a \$10.00 per ticket deposit, you can now reserve your seats for next year's race.

So, send your name, address, PHONE NUMBER (this is very important!) and number of tickets you want reserved, along with your check, made payable to AROSC, to: AROSC/LBGP, P.O. Box 261, Los Alamitos, CA 90720

Do it today!! Don't be left out!!



**lights
camera
ACTION!**

AN INVITATION
TO ALL "SUPER-8" SHOOTERS

The club is making a film documentary about the AROSC Time Trial Program; and the producers would be most grateful for any and all film footage of these events that you movie camera buffs contribute to this effort.

So come on out to the Time Trials at Riverside this year and do your thing! Who knows? This could be your chance to make it big!!

**WESCO
TRACK
& TIRE**

CROMDORA-BBS
-CAMPAGNOLO
MAGNESIUM WHEELS



PIRELLI-MICHELIN
-DUNLOP
RADIALS



including 70 series and limited quantities scarce European 60 series.
Wheel balancing and alignment to racing tolerances.

WESCO TRACK & TIRE
8441 Sepulveda
Sepulveda, California 91343
(213) 894-3700
(213) 892-5514

ALFACIONADA

Alfa Milano, Inc.



We offer you the expertise of
Mr. Aquiles Gemba
and of
Mr. Tranquillo Bulgarini,
formerly with Autodelta and
Alfa Romeo factory.

1032 S. La Cienega Blvd.
Los Angeles, CA 90035 (213) 652-2404



wanted

14 x 6 Alloy Wheels for GTV. Remember those alloy wheels you took off when you installed the new Minilites? The ones that are getting dusty in your garage. Here's your chance to unload them. I'm tired of looking at the stock steel wheels and want to liven up my 1967 GTV at low cost. Call Mike, (213) 657-5100 x 381, or 372-7752 after 7 PM.

SINCE 1967
CATALOG 4 dollars
 70 pages
ALFA ROMEO
PERFORMANCE PARTS
AND ACCESSORIES
 GTV • SPIDER • ALFETTA
SHANKLE
 15451-F Cabrillo Rd
 Van Nuys, CA 91406
 (213) 988-5190



EXPERT GENERAL SERVICE AND MAINTENANCE

A complete line of chassis and drive train components for racing and high performance street use are also available.

Service available evenings and weekends

"People who go racing come up with a lot of experience as to what can go wrong with cars"...

Alan Ward

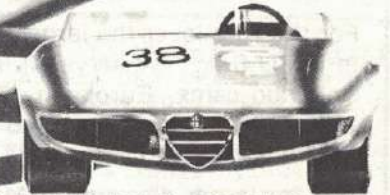

HOME OF THE FASTEST
 PRODUCTION ALFA
 ULTIMATELY RACING
 IN THE UNITED STATES

WARD & DEANE RACING

115 N. Oak No. 15 Inglewood, Ca. 90301 (213) 649-5369

SUPPORT OUR ADVERTISERS Give them the Business

AUTHORIZED
 ALFA
 ROMEO
 DEALER



BEACH IMPORTS



848 Dove Street
 Newport Beach, CA
 (714) 752-0900

Alfacionada is the monthly publication of the Alfa Romeo Owners Club of Southern California, (AROSC).

Subscriptions to this newsletter are included as part of the \$20.00 per year AROSC Membership fee. For membership information write: AROSC P.O. Box 261, Los Alamitos, CA 90720. Articles, letters, and personal ads are always welcomed and should be received by the editor 20 days prior to the monthly meeting. Meetings are normally held on the fourth Friday of the month at the ALONDRA PARK CLUBHOUSE, at 3850 Manhattan Beach Blvd., Lawndale, just east of the San Diego freeway. Date or location changes will be posted in the newsletter prior to the meeting. Meetings start promptly at 8:00 PM. For more information call:

Rick Clemente (Pres) (213) 650-4039
 Sue Bernstein (Memb) (213) 832-4764

ALFACIONADA

PAGE 13

JOHN ~~HESTER~~
 IRELAND 874.1445



Auto Dealer's Supplies

A DIVISION OF RICAMBIO, INC

6640 SAN FERNANDO ROAD
GLENDALE, CALIF. 91201
(213) 246-7263

MON - FR
8:00 - 5:00

For the Alfa lover the largest independent stock of Alfa original and O.E.M. parts in the U.S.A. We serve all 50 States and Canada. Hard to find goodies such as Colombo cams, European 1750-2000 Cams, MomoWheels, Cromodora Wheels 1600-1750 Competition Head Gaskets. Old 2000 cast iron and 2600 parts! Direct Telex service to Europe.

10% or larger discount to Alfa Owners Club Members. Dealers and shops please inquire about prices.

P.S. Fantastic Fiat Parts Department TOO!



AROSC

P.O. BOX 261 LOS ALAMITOS CA. 90720



TIME VALUE MATERIAL

BULK RATE
U.S. POSTAGE PAID
SAN PEDRO, CALIF.
PERMIT NO. 29

Barry A. Klein
4923 Burgotne Lane
La Canada, CA 91011