



# Alfacionada

Alfa Romeo Owners  
of  
Southern California

P. O. BOX 261  
VOLUME 8, NUMBER 11

A DRIVING CLUB

LOS ALAMITOS, CALIF.  
NOVEMBER 1969

## ELECTION TIME

November is the classic month for elections and we, too, will elect the 1970 AROSC Board. No variety of parties but we have lots of candidates, ready to offer their time and efforts to run our club.

The election will be held at the next club meeting, November 21. Your vote is very important, because the members you elect will be representing you and your interests in the coming year. Please make every effort to attend.

Nominated for election are:

Tom Atkins (incum.)  
Charles Camp  
Oscar DuFau  
Paul Ebeyer  
Phyllis Gaylard (incum.)  
Vince Giobbe (incum.)  
Mark Marcantoni (incum.)  
Blake Morris  
Loren Smith  
Tom Suter (incum.)  
Karen Thompson  
Alan Ward (incum.)  
Bob Jorgenson and Bill Larson

The general membership votes for ten of the above nominated to serve on the 1970 Board of Directors. The new board then elects its own officers.

## CHRISTMAS PARTY

Our annual get-together, to celebrate the start of the "Yuletide Season" or better known as the "Bang the Bumpers" party, will be held this year at the new residence of Mr. and Mrs. Tom Suter. (It will never be the same.)

The date, Saturday, December 6. Make your plans now, so you will not miss this rare event. Ladies will be required to wear dresses (too bad) and the gentlemen, coats and ties (what a pain in the neck.) After the booze gets everyone warmed up, we will allow the ties and ..... to come off!

There will be plenty to eat, music, games and beautiful door prizes. You bring your favorite booze. If you don't want to drive home and want to sleep it off in Tom's garage, bring your sleeping bag.

A special flyer about the party will be mailed separately, with all the information and map. If you do not receive the flyer by December 3, please contact a board member for the information.

---

YOU CAN START PAYING YOUR 1970 DUES AT THE NOVEMBER MEETING. SAME "OL" PRICE \$5.00.

RACING NEWS BY MARK

Over 450 victories, with fifty first overalls, are the current season results of Alfa's racing. In the turism class, Alfa has won, for the third year in a row, the "European Challenge" in the #2 division with a GTA1600 driven by Spartaco Dini. Also, first place in the smaller class was won by a GTA junior, driven by Enrico Pinto. Alfa has also clinched the "Austrian" hill climbing championship, the Czechoslovakian and is leading in other nations.

In the water, the Alfa engines have had innumerable successes winning five world championships, six Europeans, two Italian and one in France.

Locally, as you all know by now, the Alfa "33" with Scooter Patrick driving, has won seven out of eight races in class B sport racing, the only DNF was at the Santa Barbara races when the car was pushed off the track by a much heavier machine, damaging the front suspension. Of the other Alfas racing in our region, the best showing in the National standings belongs to Jeff Kline, who is first in C sedans in his fast GTA junior. Alan Ward finished fourth in class "E" prod. and Phyllis Gaylard, fifth in "C" production. Fritz Taggart won class "F" production at the recent regional race at Riverside. Our congratulations to all of them as well as to our president, Dale Jones, for a good showing in his first year of racing. He finished all the races he entered. It was no secret that all he wanted to do in his first year of racing was learn the secrets of racing and finish all races to get his regional license. "Next year things will be different!" said Dale.

ALFA ROMEO 1970 PROGRAM BY MARK

No changes are expected in the "Giulia" series or the "1300" series. The "1750" series, however, have some very interesting improvements. The changes were introduced at the recent Torino Auto Show. One consisted of the new Iodine headlights that will adjust automatically, up or down, according to the inclination of the front end due to the number of passengers in the car. The GTV has a new set of front bucket seats, with more lateral support and new head rests. The most radical change was noted in the Duetto spyder. The tail section is entirely new. Chopped off, like all recently designed Pininfarina spyders. (i.e. Ferrari, Maserati, etc.) The interior of the spyder also has been changed. New bucket seats, a head rest and a console between the seats.

The above changes are proof that Alfa Romeo is never satisfied with what already seems to be an excellent product. They are always looking for better and safer improvements. A note to eager beavers: The new models will not reach the U.S.A. for some time! They will have to go through inspections and safety checks before they can be imported. If you plan to buy a new Alfa in 1970, don't wait for the above mentioned new models.

A completely new 1300 Alfa was also introduced, with body by Zagato that will be called the "Junior Z" built on the same lines of the famous Zagato racing Alfa's ZT but with a "Sunday" look. It is just what you and I would like to drive in on Friday night down Hollywood Blvd. Seeing the picture and falling in love with it took just a matter of seconds. This is not just another experimental car, it will be a production model. My hunch is that this car was designed to replace the Bertone SS.

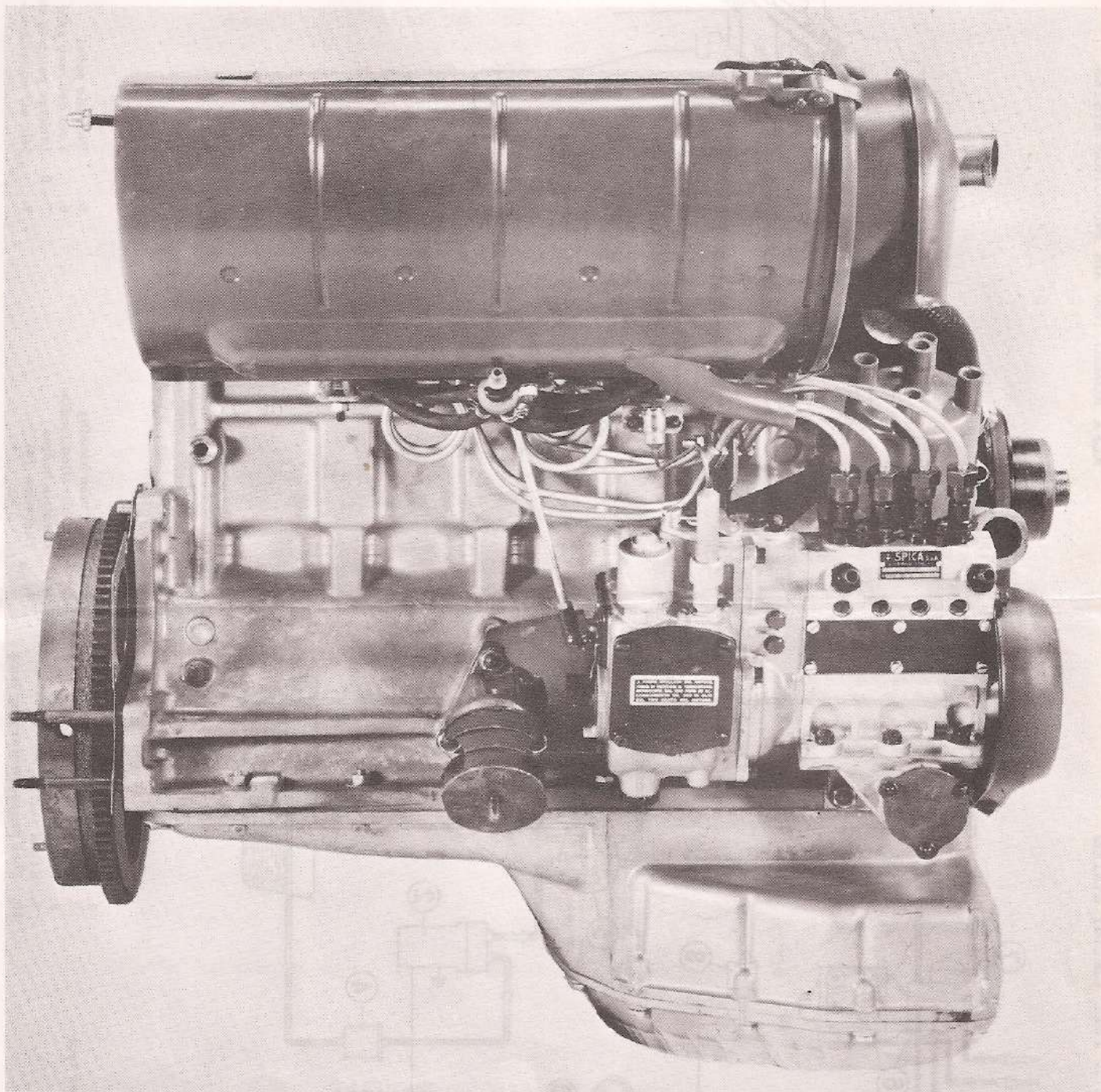

ALFA ROMEO 1779cc FUEL INJECTED ENGINE

The new fuel injected 4 cylinder twin cam engine will be standard on all models of the new 1750 line of Alfa Romeos. The 132 HP powerplant offers performance in the Alfa Romeo tradition plus the added benefits of reduced air pollution and increased economy.

ALFA ROMEO 1750 AIR INDUCTION SYSTEM

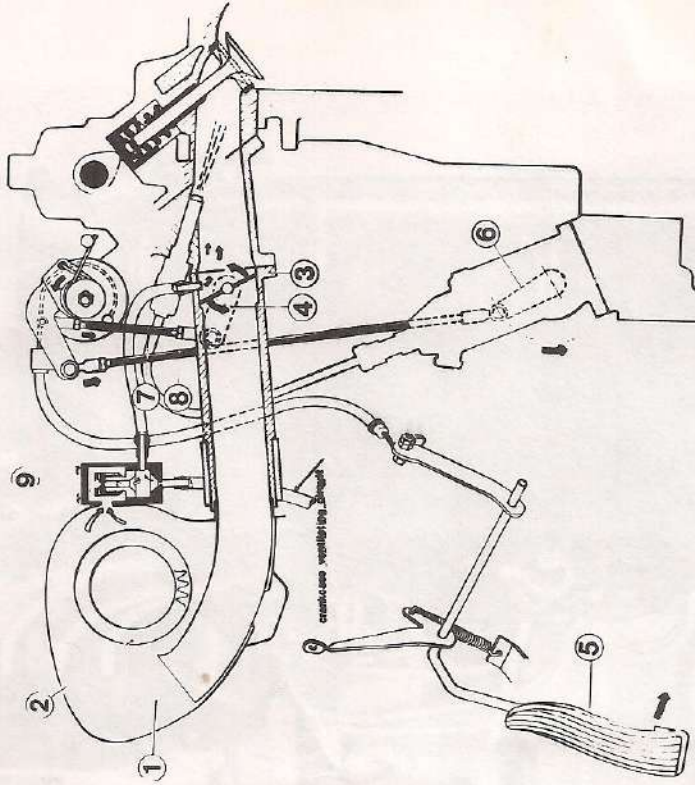

- 1. Ram tube housing
- 2. Air filtration media
- 3. Throttle bodies
- 4. Throttles (4)
- 5. Throttle pedal
- 6. Fuel delivery arm
- 7 - 8. Linkage pump to throttles
- 9. Idle air equalizers

ALFA ROMEO 1750 FUEL CIRCUIT SYSTEM

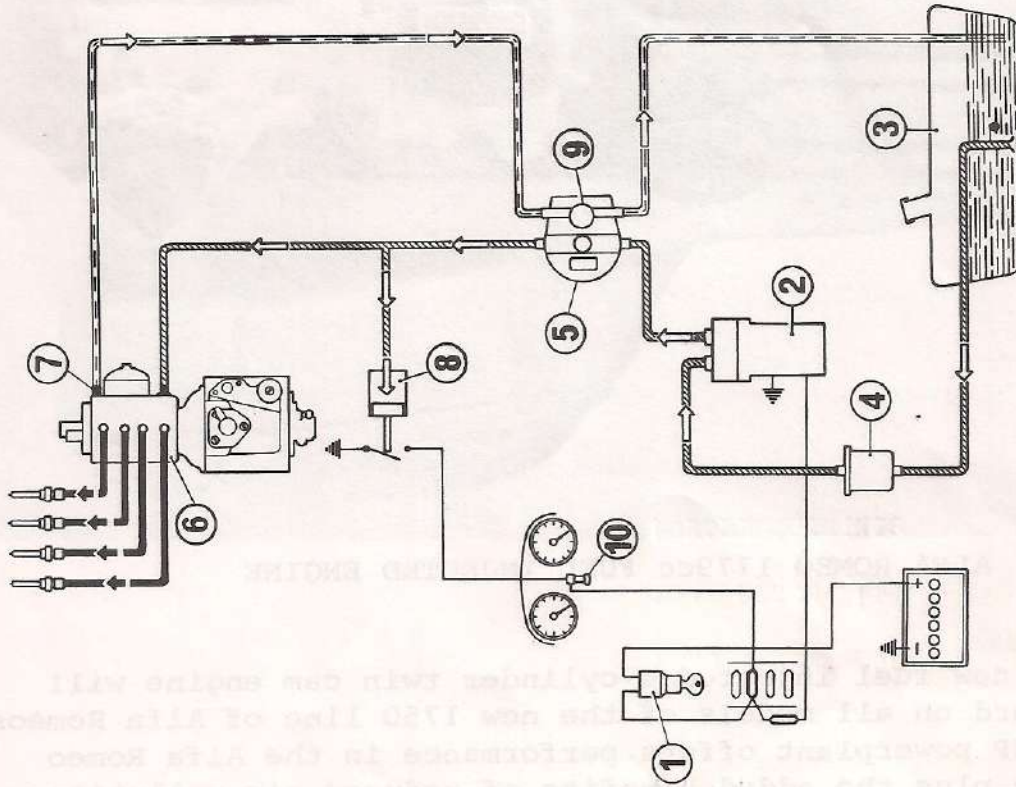

- 1. Ignition switch
- 2. Fuel supply pump, gear type
- 3. Fuel tank
- 4. Tank filter
- 5. Pump filter
- 6. Injection pump
- 7. Fuel return
- 8. Pressure sensor
- 9. Relief valve
- 10. Fuel pressure warning lamp

FOR SALE

1966 Sprint Speciale--Borrani wire wheels, FM stereo, repainted red, clean. 35,000 miles \$2,700. Beverly Curry 598-3264.

5--5x15" Borrani wire wheels. Aluminum rims, chrome spokes \$250.00. Jim Smolen. 350 E. Limberlost, Tucson, Ariz. Zip 95705 Phone 602 887-2280.

1300 CONRERO prepared twin plug head complete with distributor. Call Tom at A.R.I. El Segundo.

1958 - 2000 Spyder, body and chasis (no suspension, no engine, no box) Bill Schafer, P.O.Box 1088 Albert, N.M. Phone 505 243-7781.

GIULIA COUPE 1963. 1700cc engine 6" wide rims and tires. Recently recond. Best offer over \$1000. T. Reiner 213 377-4998.

1600 GTA NORMALE, early chassis, steel floors, L.H. drive, suspension options, radio, Q.I. lamps, trans-am mags, fresh red lacquer, etc. Straight and strong. \$3200. Call Vince Giobbe 831-4904.

COMING EVENTS

November 16 Championship slalom at Orange County Fairgrounds 4F13 HM B AC DJK EGN S2

November 21 Alfa Club Meeting Election Night

November 23 Guldsteand Slalom at Adams Go-Kart Track Riverside

December 6 Alfa Club Christmas Party

January 16 "1970" Alfa Club Meeting at ARI facilities in El Segundo (more about this later)

ALFACIONADA is the monthly publication of the Alfa Romeo Owners Club of Southern California (AROSC). Subscriptions to this newsletter are included as part of the \$5 per year AROSC membership fee. For membership information, write AROSC, P. O. Box 261, Los Alamitos, California, 90720. Articles, letters and personal ads are always welcomed for publication and should be received by the editor fifteen days prior to the monthly meeting. Meetings are held the third Friday of every month at Little Lake Clubhouse, 10900 S. Pioneer Blvd., Santa Fe Springs, just north and east of the Santa Ana Freeway, at 8:00 P.M. For further information, call Dale Jones (president) 596-2687, or Mark Marcantoni, (editor), 431-4682.

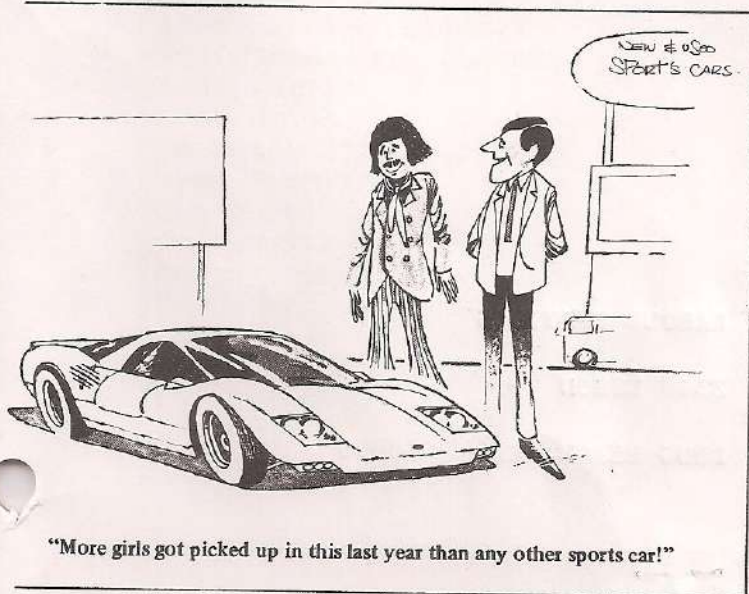



ALFA ROMEO



TEST DRIVE THE NEW 1750 ALFAS AT A DEALERSHIP WHERE SERVICE AFTER SALE IS A PLEDGE NOT A GIMMICK. WE TRY TO PLEASE!

All brands, sports and domestic car tires — Slalom and street retreading in original factory designs. Terms = All Major Credit Cards Honored.

JIM GRAY IMPORTS, Inc.

3515 ATLANTIC AVE. • LONG BEACH  
PHONE 424-0951

B & H TIRE SALES CO.  
SPORTS CAR TIRE CENTER  
PIRELLI & DUNLOP TIRE DISTRIBUTORS

508 West Anaheim St.  
Long Beach, Calif. 90813  
Phone — 437-5180

2423 So. Main St.  
Santa Ana, Calif. 92707  
Phone (714) 545-9415



ALFA ROMEO OWNERS  
of  
SOUTHERN CALIFORNIA

P. O. BOX 261 — LOS ALAMITOS, CALIFORNIA 90720



DAROLD CUMMINGS  
2348 LEMON #5  
LONG BEACH, CAL 90806